

DESIGN NOTES

LTC1387: 5V RS232/RS485 Multiprotocol Transceiver

Design Note 176

Y. K. Sim

Introduction

The LTC[®]1387 is a single 5V supply, single-port, logic-configurable RS232 or RS485 transceiver. The LTC1387 features Linear Technology's usual high data rates (120kbaud for RS232 and 5Mbaud for RS485), a loopback mode for self test, a micropower shutdown mode and $\pm 7\text{kV}$ ESD protection at the driver output and receiver inputs. This part is targeted at handheld computers, point-of-sale terminals and applications that require a minimum pin count and software-controlled multiprotocol operation.

RS232 and RS485 Interfaces

Most computers communicate with other computers, peripherals or modems through an RS232 interface, a single-ended interconnection standard. The simplest RS232 interface has three wires: a transmit data line, a receive data line and a ground return. EIA-562 is a single-ended electrical standard similar to RS232, with relaxed voltage levels.

RS485, a differential signal interface, is popular because it offers increased noise immunity, longer transmission cable length than RS232 or EIA-562 and allows multiple transceivers on a twisted pair of wires.

LT, LTC and LT are registered trademarks of Linear Technology Corporation.

Key Features

The LTC1387 offers a flexible combination of two RS232 drivers, two RS232 receivers, an RS485 driver, an RS485 receiver and an onboard charge pump to generate boosted voltages for true RS232 voltage levels from a 5V supply. Figures 1 through 4 show the LTC1387's versatility in software-controlled RS232/RS485 applications. The RS232 and RS485 transceivers are designed to share the same I/O pins for both single-ended and differential signal communication modes. Both half-duplex and full-duplex communication can be supported. Autodetection of RS232/RS485 interface is feasible via a controller software routine.

The RS232 transceiver supports both RS232 and EIA-562 standards, whereas the RS485 transceiver supports both RS485 and RS422 standards. The logic input (MODE) selects between RS232 and RS485 modes. With three additional control logic inputs (RXEN, DXEN and ON), the LTC1387 adapts easily, as shown in Table 1, to various communications needs, including a one-signal-line RS232 I/O mode.

A SLEW input pin available in RS485 mode changes the driver transition between normal and slow-slew-rate modes.

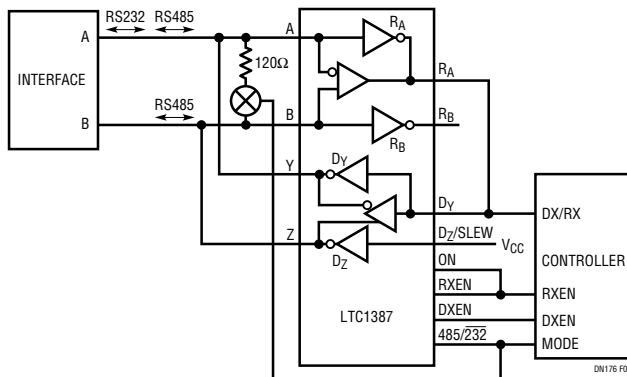

RS232 TRANSMIT MODE	RS232 RECEIVE MODE	RS485 TRANSMIT MODE	RS485 RECEIVE MODE	SHUTDOWN MODE
RXEN = 0	RXEN = 1	RXEN = 0	RXEN = 1	RXEN = 0
DXEN = 1	DXEN = 0	DXEN = 1	DXEN = 0	DXEN = 0
MODE = 0	MODE = 0	MODE = 1	MODE = 1	MODE = X

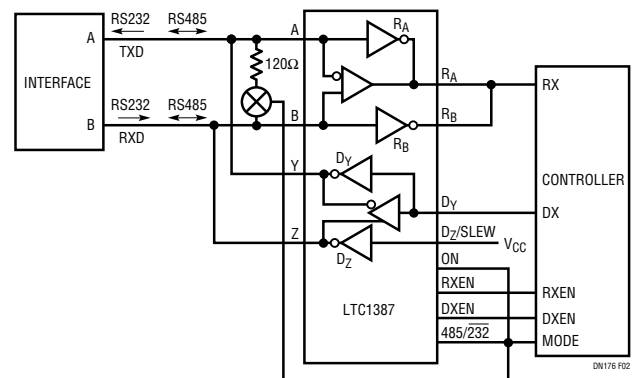

RS232 MODE	RS485 TRANSMIT MODE	RS485 RECEIVE MODE	SHUTDOWN MODE
RXEN = 1	RXEN = 0	RXEN = 1	RXEN = 0
DXEN = 0	DXEN = 1	DXEN = 0	DXEN = 0
MODE = 0	MODE = 1	MODE = 1	MODE = 0

Figure 1. Half-Duplex RS232 (1-Channel), Half-Duplex RS485

Figure 2. Full-Duplex RS232 (1-Channel), Half-Duplex RS485

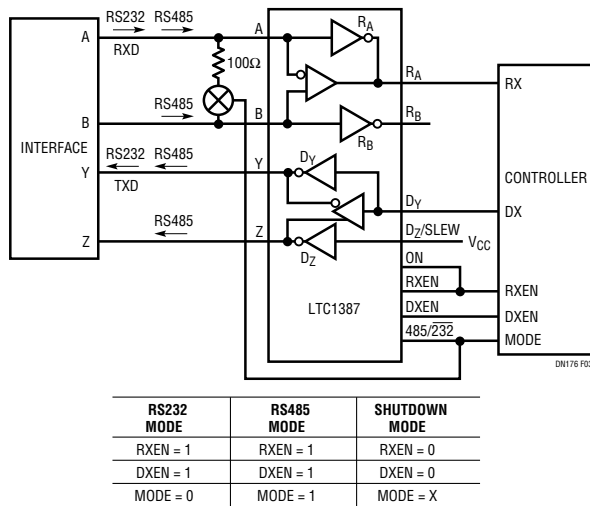

Figure 3. Full-Duplex RS232 (1 Channel), Full-Duplex RS485/RS422

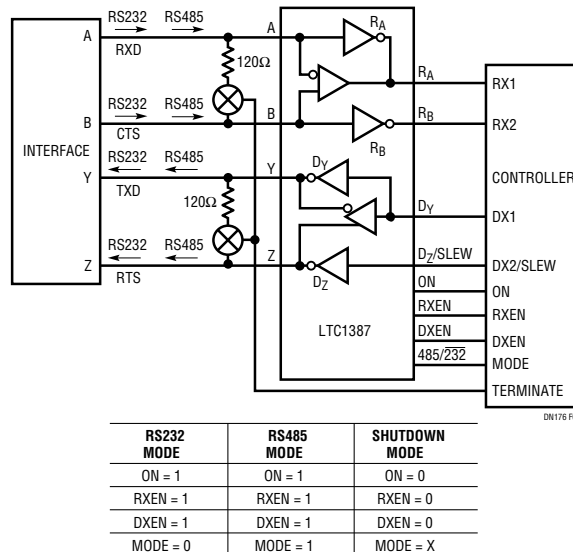

Figure 4. Full-Duplex RS232 (2 Channel), Full-Duplex RS485/RS422 with SLEW and Termination Control

Table 1. This Function Table Indicates the Logic Inputs to Configure the LTC1387 for Various RS232/RS485 Modes

SELECT INPUTS				RECEIVER		DRIVER		CHARGE PUMP	LOOPBACK	COMMENTS
ON	RXEN	DXEN	485/232	RXA	RXB	DXY	DXZ			
1	0	0	0	Hi-Z	Hi-Z	Hi-Z	Hi-Z	ON	OFF	RS232 Mode, DX and RX Off
1	0	1	0	Hi-Z	Hi-Z	ON	ON	ON	OFF	RS232 Mode, DXY and DXZ On, RX Off
1	1	0	0	ON	ON	Hi-Z	Hi-Z	ON	OFF	RS232 Mode, DX Off, RXA and RXB On
1	1	1	0	ON	ON	ON	ON	ON	OFF	RS232 Mode, DXY and DXZ On, RXA and RXB On
0	0	1	0	Hi-Z	Hi-Z	ON	Hi-Z	ON	OFF	RS232 Mode, DXY On, DXZ Off, RX Off
0	1	0	0	Hi-Z	ON	ON	Hi-Z	ON	OFF	RS232 Mode, DXY On, DXZ Off, RXA Off, RXB On
0	1	1	0	ON	ON	ON	ON	ON	ON	RS232 Loopback Mode, DXY and DXZ On, RXA and RXB On
0	0	0	X	Hi-Z	Hi-Z	Hi-Z	Hi-Z	OFF	OFF	Shutdown, RS485 R _{IN}
1	0	0	1	Hi-Z	Hi-Z	Hi-Z	Hi-Z	ON	OFF	RS485 Mode, DX and RX Off
X	0	1	1	Hi-Z	Hi-Z	ON	ON	ON	OFF	RS485 Mode, DX On, RX Off
X	1	0	1	ON	Hi-Z	Hi-Z	Hi-Z	ON	OFF	RS485 Mode, DX Off, RX On
1	1	1	1	ON	Hi-Z	ON	ON	ON	OFF	RS485 Mode, DX On, RX On
0	1	1	1	ON	Hi-Z	ON	ON	ON	ON	RS485 Loopback Mode, DX On, RX On

In normal slew mode, the twisted-pair cable is terminated at both ends to minimize signal reflection. In slow slew mode, the maximum signal bandwidth is reduced; EMI and signal reflection problems are minimized. Slow slew rate systems can often use incorrectly terminated or unterminated cables with acceptable results. If cable termination is required, external termination resistors can be connected through switches or relays.

The RS485 receiver features an input threshold between 0V and -200mV. The receiver output has a known HIGH output state if both receiver inputs are open, if the cable is shorted or if no driver is active.

Conclusion

The LTC1387 is ideal for point-of-sale terminals, computers, multiplexers, networks or peripherals that must adapt on the fly to various I/O configuration requirements without hardware adjustments.

For literature on our Interface Products, call **1-800-4-LINEAR**. For applications help, call (408) 432-1900, Ext. 2453

Linear Technology Corporation

1630 McCarthy Blvd., Milpitas, CA 95035-7417 • (408) 432-1900
FAX: (408) 434-0507 • TELEX: 499-3977 • www.linear-tech.com

dn176f LT/TP 0398 340K • PRINTED IN THE USA

© LINEAR TECHNOLOGY CORPORATION 1998